

MSI-3700 SPECIFICATIONS

MSI-3700 Magnum Plus scale (carriage attachment)

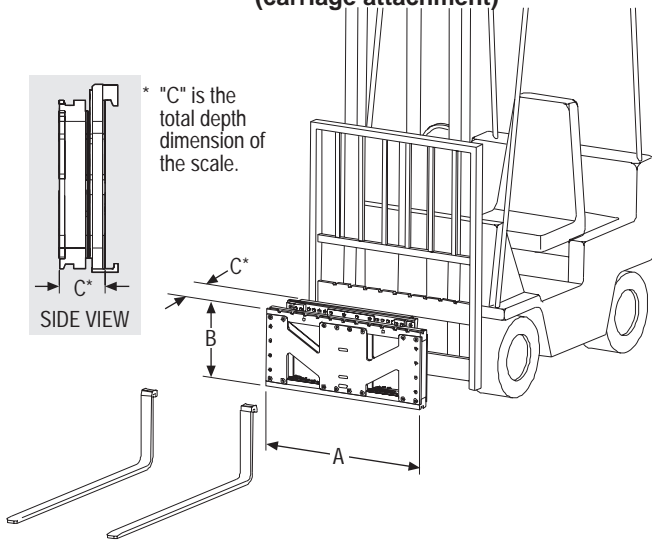

MSI-3650 Digital Weight Indicator

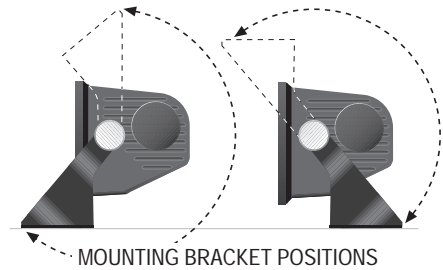
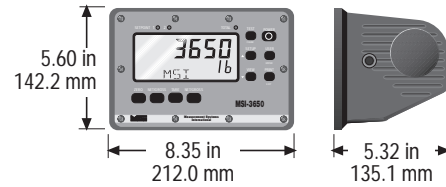

CAPACITY	RESOLUTION	TA CARRIAGE CLASS	DIMENSIONS (in / mm)			SHIPPING WEIGHT
			A	B	C	
5,000 lb 2,500 kg	2 lb 1 kg	II II	36.0 in 914.4 mm	16.0 in 406.4 mm	4.35 in 110.49 mm	180.5 lb 81.87 kg

Standard System Specifications

Scale/carriage assembly

- Rated capacity:**
Class II: 5,000 lb x 2 lb (2,500 kg x 1 kg)
- Accuracy:**
0.1% of rated capacity
- Safe Overload:**
200%
- Ultimate Overload:**
500%

Digital indicator (MSI-3650)

- Power:** 10 to 56 VDC
- Display:**
- 6 digit x 0.90 in. (23 mm) high numeric LCD (weight display)
 - 8 digit x 0.45 in. (11 mm) high alphanumeric LCD (message display)
 - 21 segment analog bar graph for level indications with NTEP option
 - LED annunciator for Totalizing and Set Point indication
 - Photocell activated backlighting

Functions:

- Power: On/Off
- Zero: zero out residual weight
- Net/Gross: switch between Net (tared) and Gross weight
- Tare: tare out empty container weight and indicate Net weights
- Total: accumulate weighments in register manually or automatically
- ViewΣ: display accumulated weighments in registers
- Print: digital output to external printer
- User: program user defined functions
- Test: display and function test
- Setup: for selection of programming functions and features

Programmable Features:

- Auto or Manual Tare entry
- Auto or Manual Totalizing
- 12 programmable ID codes (more with expanded memory option)
- Lock mode for preventing unauthorized program changes
- Pounds / kilograms mode selectable
- Digital calibration

Enclosure:

NEMA IV, IP65 alodined and powder coated cast aluminum

Operating Temperature:

- 14° to 140°F (-10° to 60°C)

Product Options:

- Class III carriage attachment 8,000 lb x 2 lb (4000 kg x 2 kg)
- Class III carriage attachment 10,000 lb x 5 lb (5000 kg x 2 kg)
- NTEP approved for legal for trade installations only available with Class II attachment. Maximum capacity of 5,000 lb x 5 lb (2,500 kg x 2 kg)
- Expanded ID Memory up to 240 ID Codes
- RS232 data output with real time clock and full output formatting
- Tape printer with truck mounting bracket (requires RS232 option)
- Internal battery power supply (2 ea. "D" alkaline batteries)
- Cable retracting and storage assembly kit with 200 inch maximum lift height (contact factory for specifications)
- Substitute standard indicator with MSI-3750 (contact factory for specifications)

Warranty:

One year



Measurement Systems

INTERNATIONAL

14240 INTERURBAN AVENUE SOUTH
SEATTLE, WASHINGTON 98168-4660 U.S.A.
Phone: 206-433-0199 • 800-874-4320 (U.S.A. only)
Fax: 206-244-8470 • URL: www.msiscalcs.com