

Accurate, Reliable Weighing for Dynamic Loading Applications



Conveyors and Mixers

CENTERLIGN weigh modules are designed for dynamic-loading applications such as conveyors, mixers, and blenders. The top mounting plate checks against the load cell when horizontal forces are applied, and the rocker pin restores the top plate to its ideal position to provide accurate, repeatable weighing.



Load Cells

Model 0745A beam load cells are stainless steel and hermetically sealed with IP68 protection. They are ideal for harsh industrial environments such as food or pharmaceutical production facilities. The "blind" load-introduction hole provides optimum loading conditions for accurate weighing.



Bumper Stops

Each CENTERLIGN weigh module has three adjustable bumper stops to check the system horizontally. When the "live" stops touch the "live end" of the load cell, they do not cause a live-to-dead shunt of the load and do not interfere with weighing accuracy.

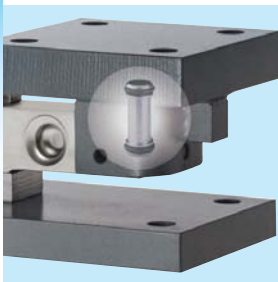

Self-Restoring Rocker Pin

The rocker pin introduces loads to the load cell, providing accurate weighing even when there are strong horizontal forces. As the top plate moves laterally away from its ideal position, the rocker pin provides a proportional restoring force to push the top plate back to its ideal position.



0958 CENTERLIGN™ Weigh Module

CENTERLIGN weigh modules enable you to convert a conveyor, mixer, or other dynamic-loading system into a weighing scale. Regardless of the application, these easy-to-install weigh modules deliver accurate and reliable performance.

- Capacity range: 250 - 10,000 lb (110 - 4400 kg).
- Rocker-pin load introduction for best accuracy.
- Hermetically sealed stainless steel load cells (not 0744).
- Painted or stainless steel mounting hardware.
- Locating tool provided for easy installation.
- Global approvals standard on load cells (not 0744).

0958 Weigh Module Specifications

Weigh Module Parameter		Unit of Measure	Specification					
Model No.			0958 CENTERLIGN					
Rated Capacity		kg (lb)	113 (250)	220 (500)	550 (1250)	1100 (2500)	2200 (5000)	4400 (10000)
Load Limit, Safe ⁹	Carbon Steel	kN (lb)	1.7 (375)	3.3 (750)	8.3 (1875)	16.7 (3750)	29.8 (6700)	59.2 (13300)
	Stainless Steel	kN (lb)	1.7 (375)	3.3 (750)	8.3 (1875)	16.7 (3750)	23 (5160)	52 (11700)
Restoring Force ⁵		%A.L./mm (.../in) ³	4.4 (111)					
Max. Horizontal Force, Carbon Steel	Transverse ⁶	kN (lb)	1.1 (250)	2.2 (500)	5.6 (1250)	6.7 (1500)	6.7 (1500)	6.7 (1500)
	Longitudinal ⁷	kN (lb)	1.1 (250)	2.2 (500)	5.6 (1250)	11.1 (2500)	17.8 (4000)	20 (4500)
Max. Horizontal Force, Stainless Steel	Transverse ⁶	kN (lb)	1.1 (250)	2.2 (500)	5.6 (1250)	5.6 (1250)	5.6 (1250)	5.6 (1250)
	Longitudinal ⁷	kN (lb)	1.1 (250)	2.2 (500)	5.6 (1250)	11.1 (2500)	14.8 (3333)	16.7 (3750)
Max. Top Plate Travel	Transverse	± mm (in)	2.5 (0.10)					
	Longitudinal	± mm (in)	2.5 (0.10)					
Max. Uplift Force ⁸		kN (lb)	0 (0)					
Weight (including load cell), nominal		kg (lb)	7.2 (16)			7.6 (17)		17 (37)
Material			carbon steel & 304 stainless steel					

Load Cell Parameter		Unit of Measure	Specification					
Model No.			0744			0745A		
Rated Capacity (R.C.)		kg (lb)	113 (250)	220 (500)	550 (1250)	1100 (2500)	2200 (5000)	4400 (10000)
Rated Output		mVV @ R.C. -kg	2 ± 0.002			1.940 ± 0.002		
		mVV @ R.C. -lb	2 ± 0.002			2.000 ± 0.002		
Combined Error ¹		%R.C.	≤ 0.03			≤ 0.018 ²		
Temperature Effect on	Min. Dead Load Output	%R.C./°C (.../°F)	≤ 0.003 (0.0017)			≤ 0.002 (0.001)		
	Sensitivity	%A.L./°C (.../°F)	≤ 0.0014 (0.0008)			≤ 0.0009 (0.0005) ²		
OIML/European Approval ⁴	Class		- C3					
	nmax		- 3000					
	Vmin	kg (lb)	-	0.032 (0.070)	0.079 (0.175)	0.159 (0.35)	0.317 (0.70)	0.635 (1.40)
NTEP Approval ⁴	Class		- III M					
	nmax		- 5000					
	Vmin	kg (lb)	-	0.032 (0.070)	0.079 (0.175)	0.159 (0.35)	0.317 (0.70)	0.635 (1.40)
ATEX Approval ⁴	Rating		- II 2 GD EEx ia IIC T4 T1 75°C ; II 3 GD EEx nL IIC T4 T1 35°C ; II 3 GD EEx nA T4 T1 35°C IP65					
Factory Mutual Approval ⁴	Rating		IS/I,II,III/1/ABCDEF/G/T4 ; NI/1/2/ABCD/T6 ; S/II,III/2/FG/T6					
Excitation Voltage	Recommended	V AC/DC	5 ~ 15					
	Maximum	V AC/DC	20					
Terminal Resistance	Excitation	Ω	≥ 385					
	Output	Ω	350 ± 2					
Material	Spring Element		Stainless steel					
	Type		Potted			Welded		
Protection	IP Rating		IP67			IP68		
	NEMA Rating		NEMA 6/6P					
	Load Limit		150					
	Ultimate	%R.C.	300					

¹ Error due to the combined effect of non-linearity and hysteresis.

² Typical values only. The sum of errors due to combined error and temperature effect on sensitivity comply with the requirements of OIML R60 and NIST HB44.

³ A.L. = Applied Load.

⁴ See certificate for complete information.

⁵ % of Applied Load (A.L.) per mm (in) displacement of the top plate (transverse and longitudinal).

⁶ Maximum horizontal force that can be applied to the top plate in a direction transverse to the longitudinal axis of the load cell.

⁷ Maximum horizontal force that can be applied to the top plate in a direction parallel to the longitudinal axis of the load cell towards the nose of the load cell only (one direction only).

⁸ Maximum vertical uplift force that can be applied to the top plate.

⁹ Maximum vertical downward force that can be applied to the top plate.



Produced in a facility that is



0958 Weigh Module Dimensions

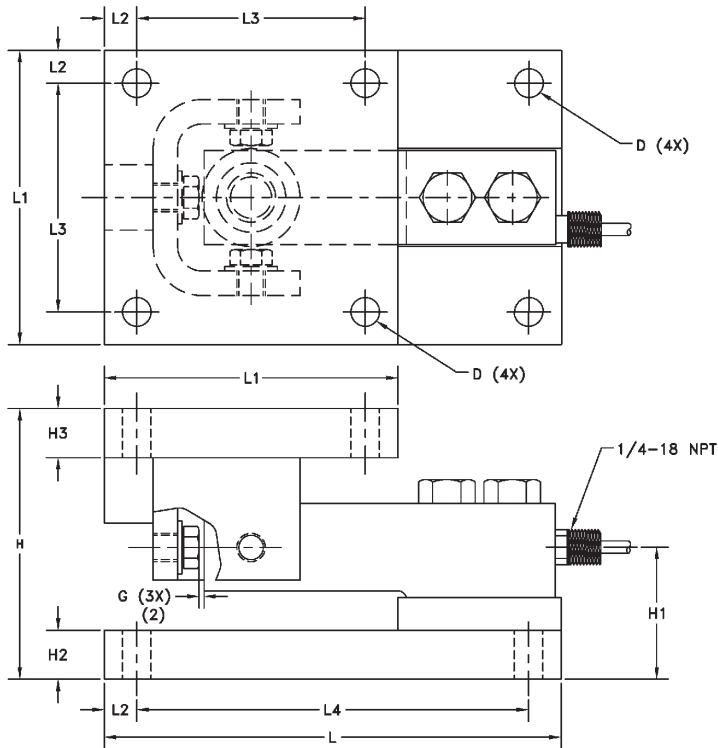

0958 Mounting Arrangements

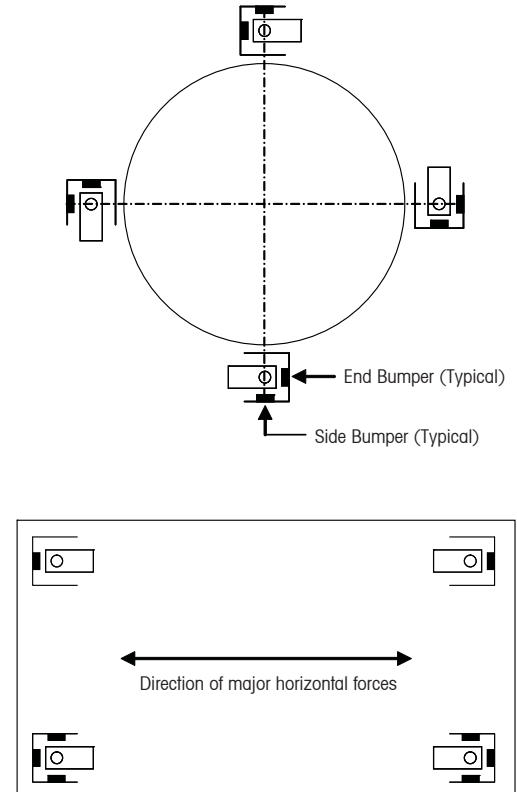

¹ Dimensions are in mm (inches).

² Reduce the number of washers under the head to increase gap to maximum dimension "G Max".

Capacity	Dimensions and Locations										Top Plate Travel	
	D	H	H1	H2	H3	L	L1	L2	L3	L4	G (as shipped)	G Max ²
110-1100 kg (250-2500 lb)	11.2 (0.44)	104.4 (4.11)	47.7 (1.88)	19.0 (0.75)	19.0 (0.75)	177.8 (7.00)	114.3 (4.50)	12.7 (0.50)	88.9 (3.50)	152.4 (6.00)	1.6 (0.06)	2.5 (0.10)
2200 kg (5000 lb)	11.2 (0.44)	105.2 (4.14)	51.3 (2.02)	19.0 (0.75)	19.0 (0.75)	177.8 (7.00)	114.3 (4.50)	12.7 (0.50)	88.9 (3.50)	152.4 (6.00)	1.6 (0.06)	2.5 (0.10)
4400 kg (10000 lb)	17.5 (0.69)	136.6 (5.38)	67.1 (2.64)	25.4 (1.00)	31.8 (1.25)	235.4 (9.25)	152.4 (6.00)	25.4 (1.00)	101.6 (4.00)	184.1 (7.25)	1.6 (0.06)	3.2 (0.12)

0958 Cable Colors

Color	Function
Green	+ Excitation
Black	- Excitation
White	+ Signal
Red	- Signal
Yellow	Shield

0958 CENTERLIGN Weigh Module Ordering Information

Contact your local sales representative for ordering numbers, pricing, and availability.

Global Approvals

Model 0745A load cells have global certifications for metrological performance and hazardous area applications. There is no need for options or additional charges.

ServiceXXL
Tailored Services

Tailored Services

Our qualified and equipped specialists are committed to providing timely local and personal service, backed by global depth and expertise. Choose from our ServiceXXL portfolio to tailor a program that meets your needs and budget. You will get professional, factory service with superior results, ensuring maximum benefit from your weighing system.

Mettler-Toledo, Inc.

1900 Polaris Parkway
Columbus, Ohio 43240
Tel. (800) 786-0038
(614) 438-4511
Fax (614) 438-4900

Specifications subject to change without notice.

© 2008 Mettler-Toledo, Inc.

METTLER TOLEDO® is a trademark of Mettler-Toledo, Inc.

2M0708
I06-TH03460.OE



Weigh-Connect-Control-Comply

METTLER TOLEDO embeds intelligence into weighing applications. Our industry leading scale electronics enable users to integrate their gravimetric measurement with applications running on PCs, PLCs, or DCS systems. Our products are designed specifically for industries subject to regulatory controls, such as pharmaceutical, chemical, food and beverage, and has been confirmed by multiple global agency standards including UL, CE, NTEP, and OIML.

www.mt.com

For more information